

Rotax 912 & 914 Series Engines Replacement of Flywheel Hub Washer

In response to an Emergency Airworthiness Directive issued by EASA on the 15th April 2011 (2011-0067-E) the UK CAA has just issued an Emergency Mandatory Permit Directive (EMPD 2011-003-E) which requires the replacement of a faulty washer (part No. 944072, item 2 on accompanying drawing) fitted to some recently assembled Rotax 912 & 914 engines.

Owners of 912 & 914 engines should check the serial numbers of their engines to see if the EMPD applies.

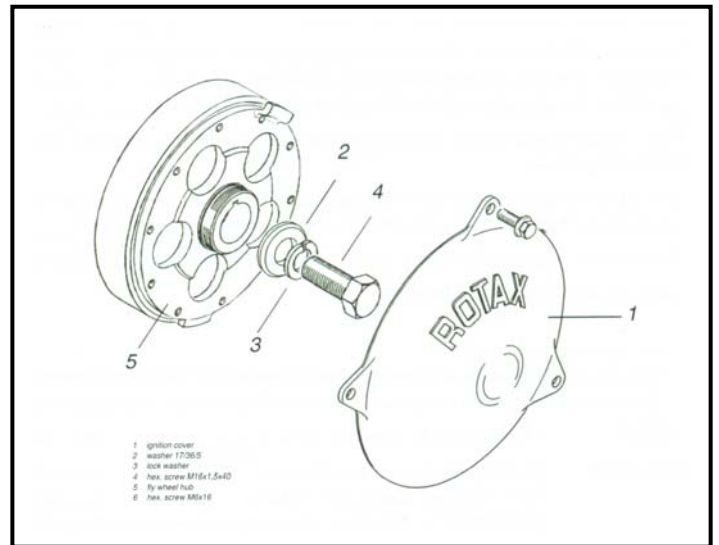

The reason for this replacement is that it has been discovered that there was a deviation in the hardening process during the manufacture of a batch of these washers. This change in hardness could lead to cracking and failure which could lead to the loosening of the flywheel resulting in ignition failure or engine damage.

The Emergency MPD can be downloaded [HERE](#)

The Emergency AD can be downloaded [HERE](#)

The Rotax Service Bulletin containing all the affected engine serial numbers can be downloaded [HERE](#)